

# Casambi Mesh 0-10V Outdoor Controller with Long Range Antenna

## Overview

- Single Channel Controller with 0-10VDC Dimming Output
- Integral Long Range Antenna
- Z10 0-10V or Zhaga Book 18 Base Options
- Compatible with Casambi Wireless Mesh Systems
- Features High End Trim Adjustment, Zoning & Continuous Dimming
- Optional Load Control Output (active high)
- Powered by 12 to 24 VDC
- IP65 Rated for Outdoor or Indoor Applications
- Mounts to Light Fixture/Luminaire via Quick Connect Receptacle
- ioXt Alliance Cybersecurity Certification

## Applications

The PSC-ZKV-WCM/EXA products are single channel wireless fixture controllers with a long range antenna. Two different base versions are available for flexibility. The Z10 Base (-100) model has an active high output for relay control.

The controller is IP65 rated for exterior use and suitable for a variety of indoor and outdoor applications in temperatures ranging from -22° to 158°F (-30° to 70°C).

This device is controlled wirelessly via Casambi Mesh technology allowing for wireless dimming of LED lighting. The compact size allows for seamless integration to the fixture.

## Accessories

**Power Pack:** The PSC-ZKV-WCM-100-BLE-CB/EXA operates on 12 to 24 VDC input. See the mwConnect PacWave™ Power Pack products for low voltage power supply options.

Alternatively, the controller can also operate with a driver that has auxiliary output (12 to 24VDC).

## Operation

**Casambi Wireless Mesh Controls:** The controller connects to a wireless mesh network via a mobile app, available as iOS or Android, to allow initial setup and subsequent parameters adjustments.

**User Interface:** Using the mobile app, features include: setup, control real time feedback, and scheduling without a gateway or internet access.

**Single Channel:** The controller outputs a 0-10V dimming channel for driver control.

**Relay Control:** 10-22VDC active high output to control relays or other control circuitry (-100 model only).

**Quick Connector:** The controller mounts to a Z10 0-10V receptacle (mwConnect part# ZKV-R1L) or Zhaga Book 18 receptacle. One receptacle is required for mounting each controller.

See the mwConnect Casambi Commissioning User Manual for more information.



For Indoor or Outdoor use



## Summary

**Product Type:**  
Single Channel Wireless Fixture Controller with Long Range Antenna

**Input Voltage | Current Consumption:**  
12 to 24 VDC | 100 mA

**0-10V Dimming Output:** 30 mA

**Load Control Output—Active High**  
Vin-2.5 V 30 mA (-100 model only)

**Fixture Mount:** Quick-Connect receptacle, sold separately

**Max Bluetooth Range<sup>1</sup>:**  
950 feet (290 meters)

**Operating Temperature:**  
-22°F to 158°F (-30°C to 70°C)

**Storage Temperature:**  
-40°F to 185°F (-40°C to 85°C)

**Relative Humidity:**  
90-95% non-condensing at 30°C

**Color:** Clear/Transparent Housing

**Warranty:** 5 years

Note:

1. Bluetooth Range is highly dependent on the integration of fixtures, surrounding environment and conditions. It is recommended to conduct testing for Bluetooth range accuracy.

Project

Location/Type

Physical Dimensions

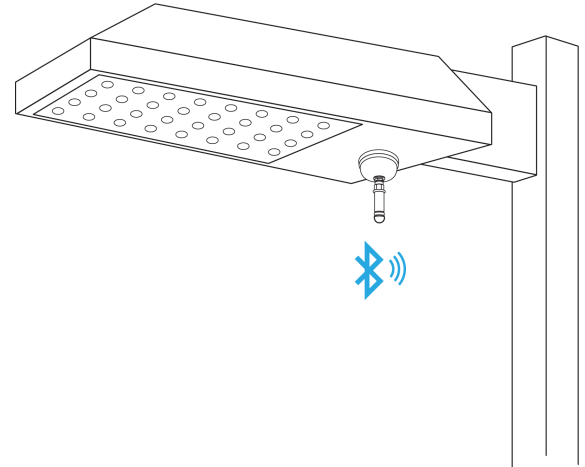
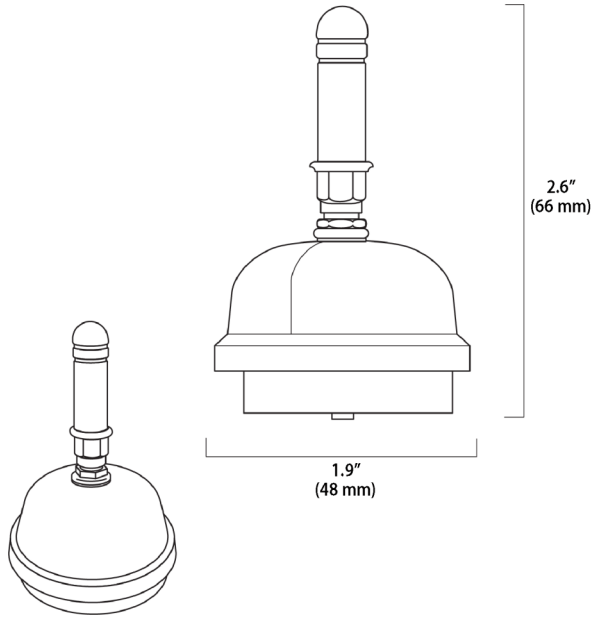

Drawings are not to scale

Product Wiring—Z10 0-10V Base (-100) Model

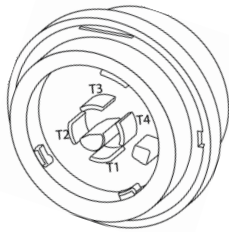

View of Back of Device

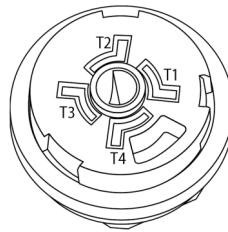

View of Z10 0-10V Device Receptacle

Tab/Slot	Designation	Notes
T1	12-24VDC+ Power to Sensor-Controller	Red Wire (ZKV-R1L Receptacle)
T2	12-24VDC- Power and 0-10VDC-/Common	Black Wire (ZKV-R1L Receptacle)
T3	0-10VDC+ Control Signal from Sensor-Controller	Purple (Violet) Wire (ZKV-R1L Receptacle)
T4	10-22VDC 30mA Load Control Output (Active High)	Yellow Wire (ZKV-R1L Receptacle)

Product Wiring—Zhaga Book 18 Base (-200) Model

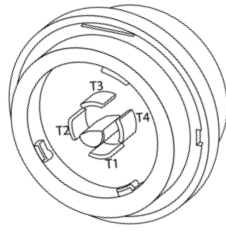

View of Back of Device



View of Zhaga Book 18 Device Receptacle

Tab/Slot	Designation
T1	12-24VDC+ Power to Sensor-Controller
T2	12-24VDC- Power and 0-10VDC-/Common
T3	Reserved
T4	0-10VDC+ Control Signal from Sensor-Controller

For Wiring Diagrams featuring the PSC-ZKV product series, visit the following link:

<http://mwconnect.us/wiring/PSC-ZKV>

Installation Of Sensor-Controller

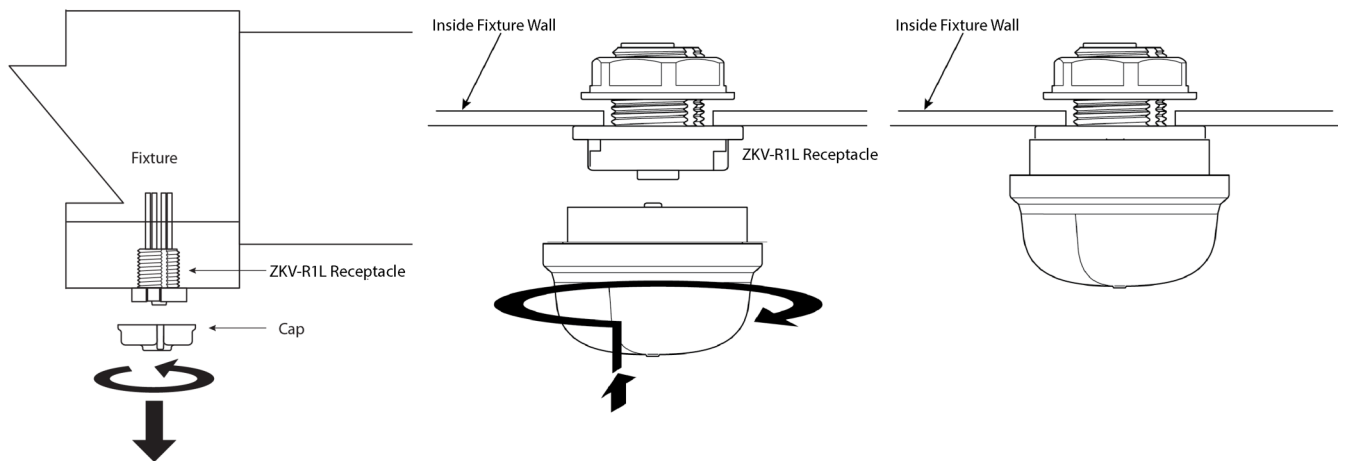

To install a ZKV device, first remove the protective cap on the ZKV-1RL or Zhaga Book 18 receptacle by pushing up and rotating counterclockwise.

To install ZKV devices insert, push in and rotate clockwise to lock. No tools are required. Luminaires can be easily and quickly upgraded.

The receptacle for ZKV devices is typically installed by luminaire manufacturer and is shipped to job site with a protective cap.

**How To Order**

Model No.	Description	Input Voltage	Output
PSC-ZKV-WCM-100-BLE-CB/EXA	Casambi Mesh 0-10V Dimming Controller with Z10 0-10V Base and Long-Range Antenna, Clear Housing	12-24VDC	Load Control 0-10V Dimming
PSC-ZKV-WCM-200-BLE-CB/EXA	Casambi Mesh 0-10V Dimming Controller with Zhaga Book 18 Base and Long-Range Antenna, Clear Housing	12-24VDC	0-10V Dimming
PSC-ZKV-R1L	ZKV Z10 0-10V Quick-Connect Receptacle for use with Controllers, Black Finish		
PSC-ZAD-R1L	Zhaga Book 18 Quick-Connect Receptacle for use with Controllers, Black Finish		

For Line to Low Voltage Power Supply/Controller, please see mwConnect PacWave™ Power Pack data sheets. Design and specifications are subject to change without notice.