

Wireless Fixture Controller with Quick Connector



For Indoor Or Outdoor Use
Receptacle Sold Separately

Overview

- 1-Channel 0-10VDC Dimming
- Mounts On Fixture
- Casambi Wireless Mesh
- High-End Trim, Zoning, Continuous Dimming, Photocell (ZKV-110 version)
- Sensor Output (active high)
- IP-65 Rated Outdoor And Indoor Applications
- Quick Connector For Easy Installation
- ioXt Alliance Cybersecurity Certification
- Powered by 12-24VDC

Applications

The PSC-ZKV-WCM-100-BLE-CB and the PSC-ZKV-WCM-110-BLE-CB are a series of 1-Channel Wireless Fixture Controllers. Both versions have active high outputs for relay control.

The controllers are IP65 rated for exterior use. They are suitable for a variety of indoor and outdoor applications in temperatures ranging from -40° to 70°C. The PSC-ZKV-WCM-110-BLE-CB version also has an integral photosensor.

These devices are controlled wirelessly via Casambi Mesh technology allowing for wireless dimming of luminaires. The compact size allows for seamless integration to the fixture.

Accessories

Power Pack: The PSC-ZKV-WCM-100-BLE-CB and the PSC-ZKV-WCM-110-BLE-CB operates on 12-24VDC input and require a separate mwConnect PacWave™ power pack. See mwConnect PacWave™ Power Pack data sheets.

Alternatively, the unit can also operate with a driver that has an auxiliary output (12 or 24VDC).

Operation

Casambi Wireless Mesh Controls: The controller connects to a wireless mesh network via a mobile app, available as iOS or Android, to allow initial setup and subsequent parameters adjustments.

User Interface: Using the mobile app, features include: setup, control real time feedback, and scheduling without a gateway or internet access.

1-Channel: Outputs 0-10 dimming channel for driver control.

Relay Control: 10-22VDC active high output to control relays or other control circuitry.

Photosensor (PSC-ZKV-WCM-110-BLE-CB version only): Features a single setpoint for ambient light detection for automated control.

Quick Connector: The controller mounts to a receptacle (mwConnect part# ZKV-R1L). One receptacle is required for mounting each controller.

See the mwConnect Casambi Commissioning User Manual for more information.



Summary

Product Type:
1-Channel Fixture Controller
(-110-model includes photosensor)

Input Voltage | Current Consumption:
12-24 VDC | 100 mA

0-10VDC Output: 30 mA

Load Control Output—10-22VDC 30mA
(Active High)

Fixture Mount: Mounts to mwConnect PSC-ZKV-R1L receptacle, sold separately.

Max Wireless Range¹:
100ft (30.4m)

Operating Temperature:
-30° C to 70° C

Storage Temperature:
-40° C to 85° C

Relative Humidity:
90-95% non-condensing at 30° C

Color: Brown (standard default), Black or White

Warranty: 5 years

Note:

1. Wireless range is highly dependent on the integration of fixtures, surrounding environment and conditions. It is recommended to conduct testing for range accuracy.

Project

Location/Type

Physical Dimensions

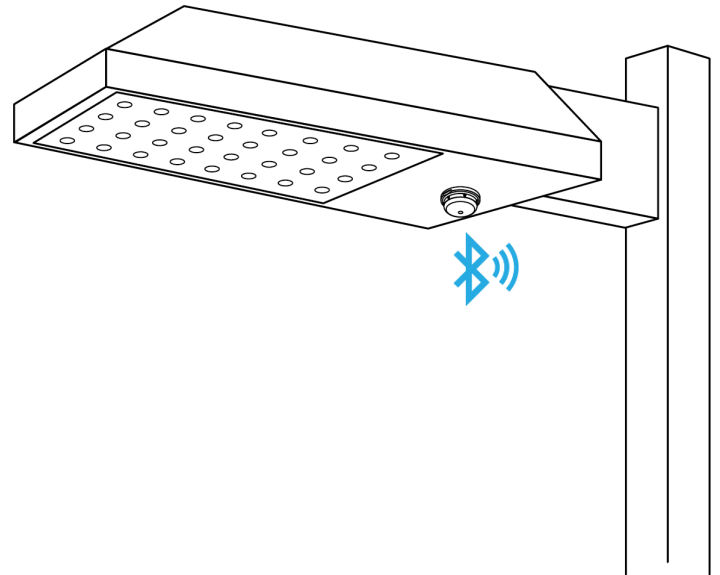
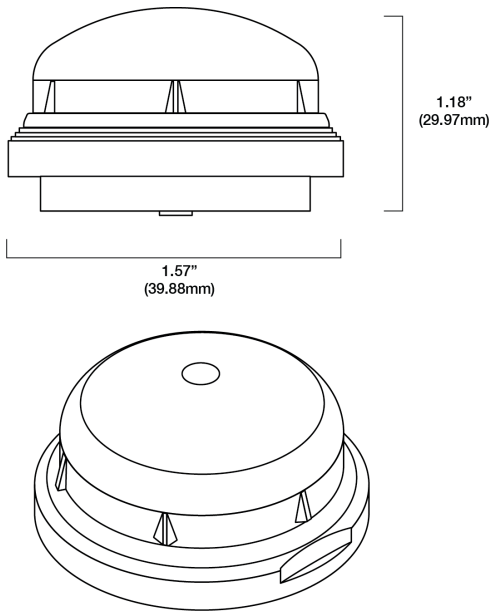

Drawing Are Not To Scale

Installation Of Controller

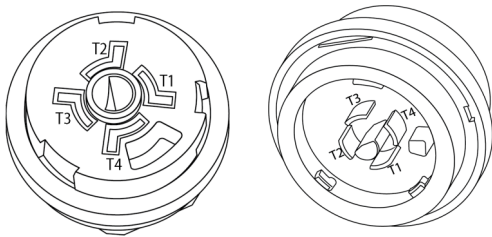

Tab/Slot	Designation	Notes
T1	12-24VDC+ Power To Controller	Red Wire (Receptacle)
T2	12-24VDC- Power And 0-10VDC-/Common	Black Wire (Receptacle)
T3	0-10VDC+ Control Signal From Controller	Purple (Violet) Wire (Receptacle)
T4	Vin-2.5V 30mA Load Control Output (Active High)	Yellow Wire (Receptacle)

The receptacle for ZKV controller is installed at fixture manufacturer and is shipped to job site with a protective cap.

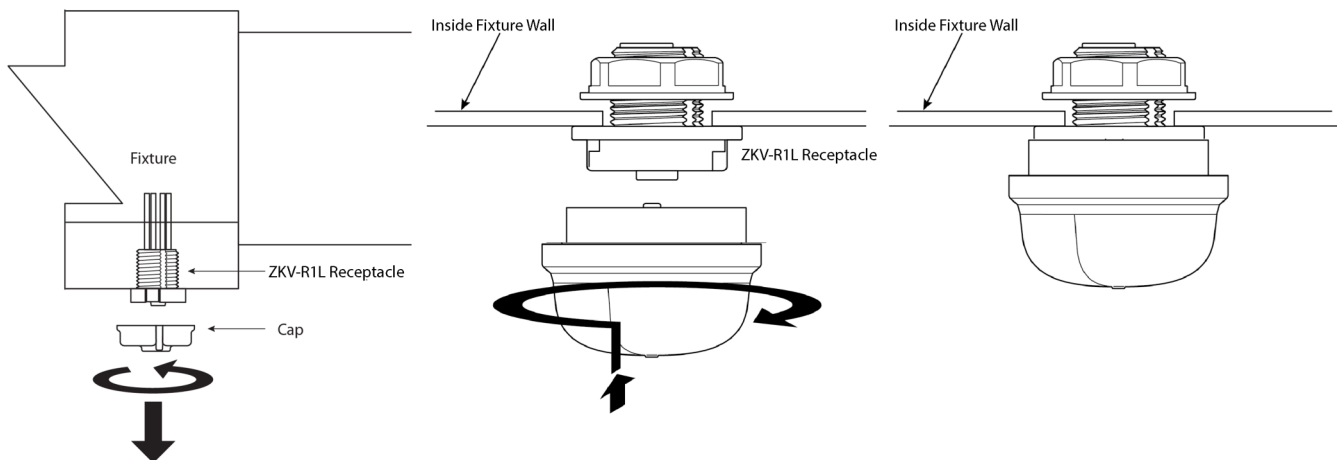

To install ZKV controller, first remove the protective cap on the ZKV-1RL receptacle by pushing up and rotating counterclockwise.

To install ZKV controller insert, push up and rotate to lock. No tools required. Luminaires can be easily and quickly upgraded.

**Example Application: Controller Installed With Power Pack
(mwConnect PSC-AC-PP-700 or PSC-AC-PP-900:) - Single Fixture**

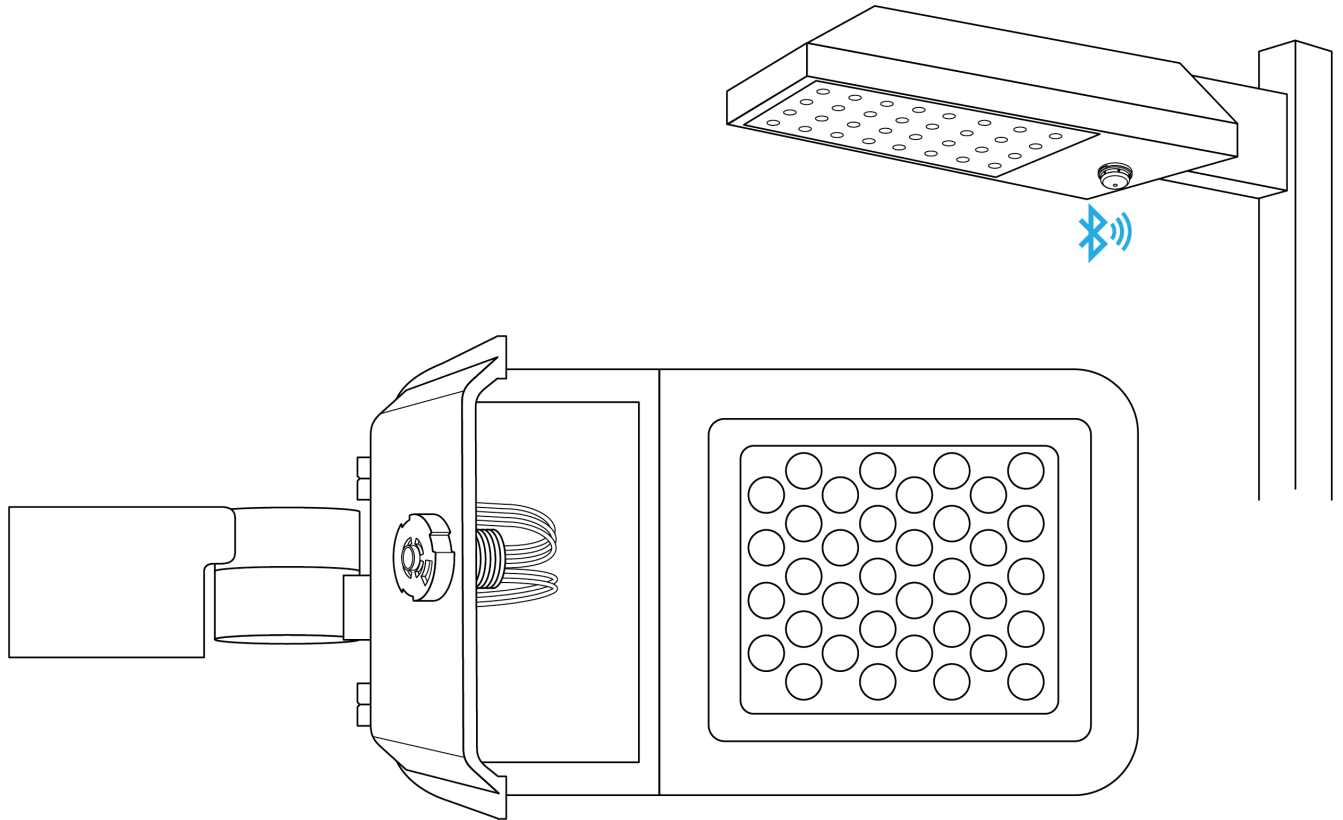

ZK-R1L receptacle on outside of fixture

Drawings Are Not To Scale

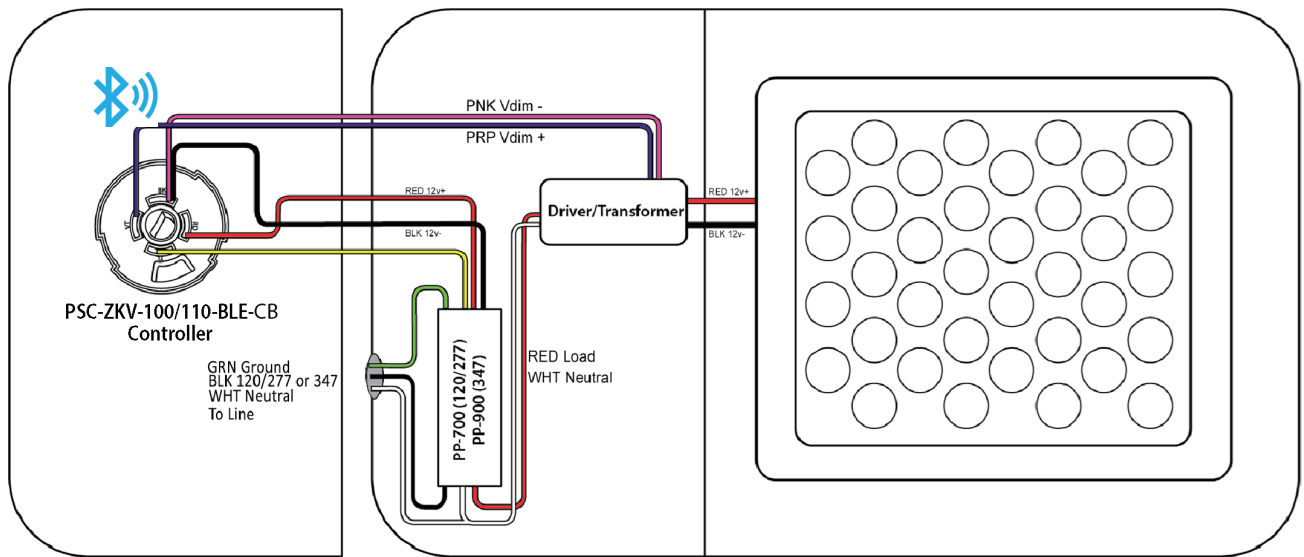

ZKV-R1L receptacle with PP-700 power pack, and LED dimmable driver
(open wiring compartment)

Example Application: Controller Installed With Power Pack
(mwConnect PSC-AC-PP250) Single Fixture With Multiple Drivers

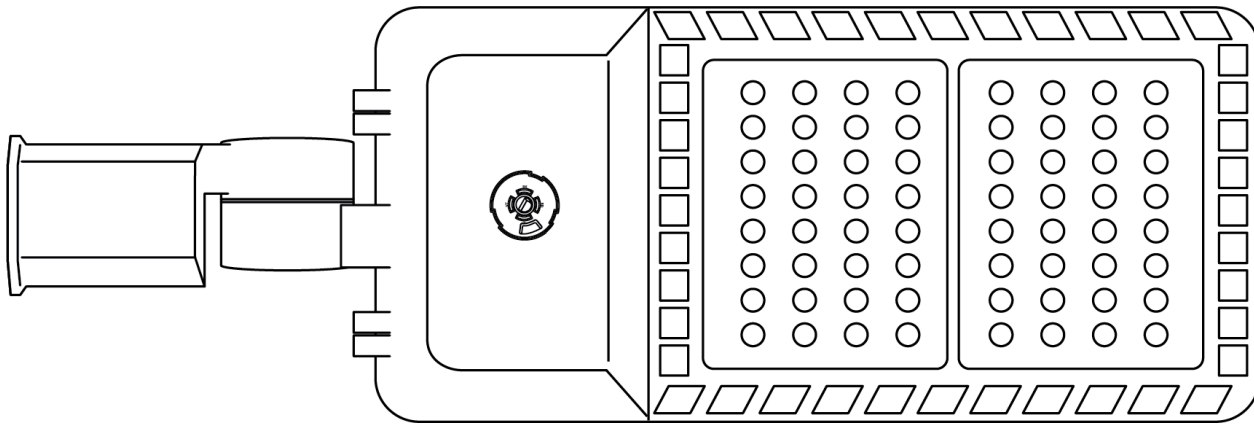
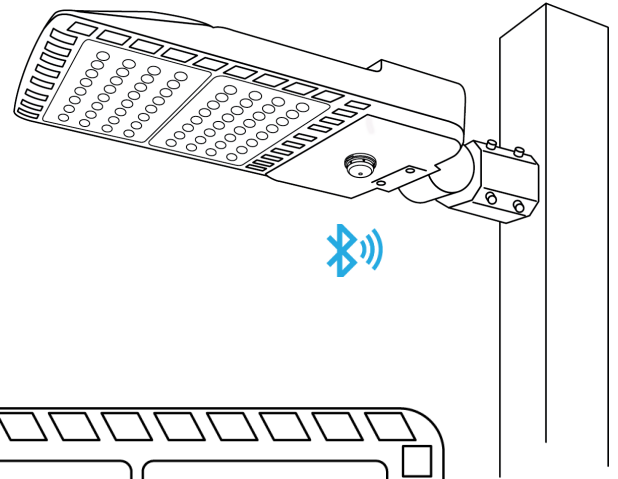

ZKV-R1L Receptacle on outside of fixture

Drawings Are Not To Scale

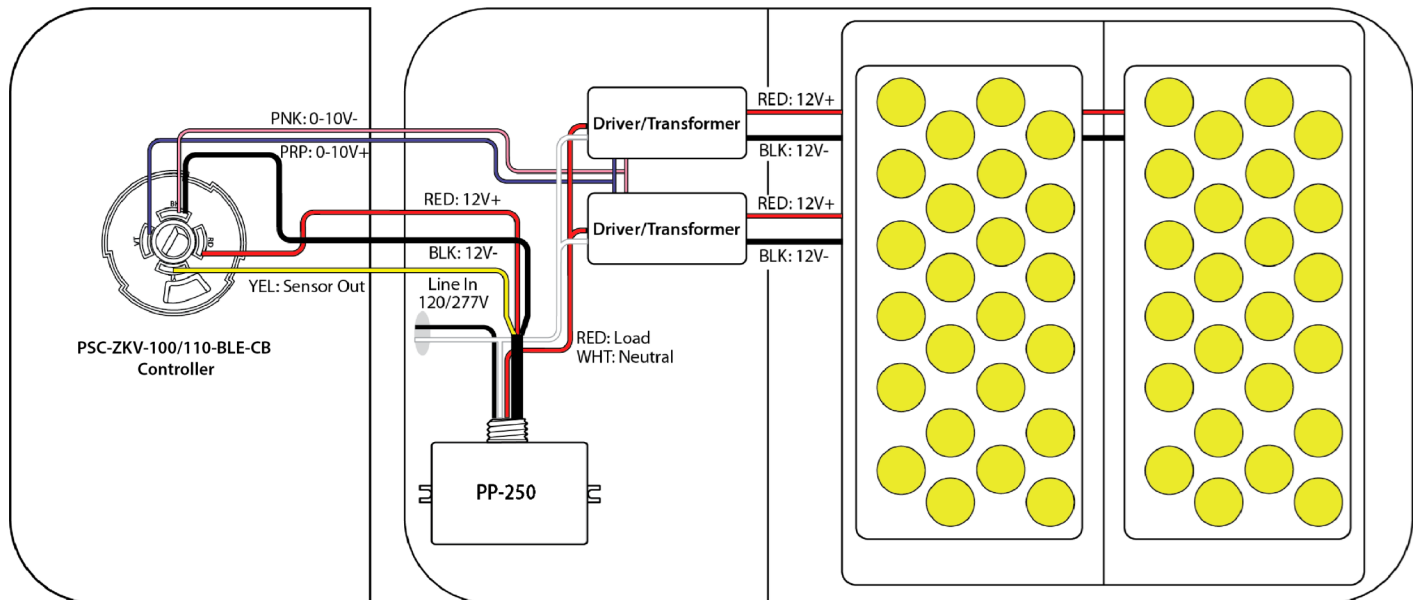

ZKV-1RL Receptacle with PP-250 power pack, and LED dimmable driver
(open wiring compartment)

Example Application: Controller Installed With 0-10V Dim-To-Off Driver With 12VDC Auxiliary Output

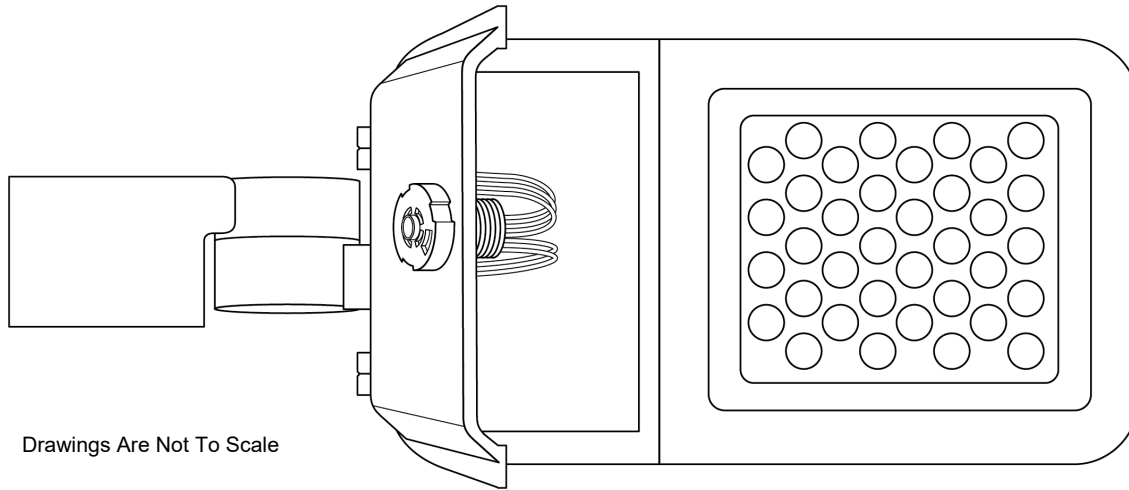

Drawings Are Not To Scale

ZKV-R1L Receptacle on outside of fixture

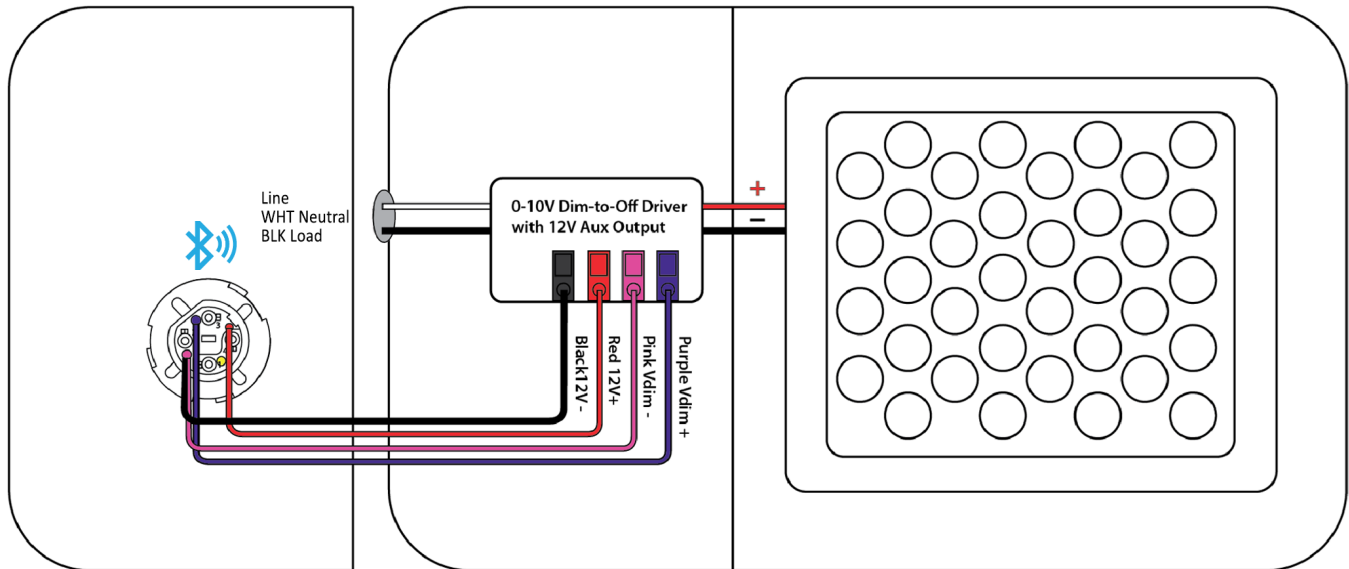

How To Order

Model No.	Description	Input Voltage	Output
PSC-ZKV-WCM-100-BLE-CB-BN	Fixture Controller with 0-10V Dimming, Wireless Mesh, standard Brown Color	12-24VDC	Control High 0-10V Dimming
PSC-ZKV-WCM-110-BLE-CB-BN	Fixture Controller with 0-10V Dimming, Light Sensing, Wireless Mesh, standard Brown Color	12-24VDC	Control High 0-10V Dimming
PSC-ZKV-WCM-100-BLE-CB-WT	Fixture Controller with 0-10V Dimming, Wireless Mesh, White Color,	12-24VDC	Control High 0-10V Dimming
PSC-ZKV-WCM-110-BLE-CB-WT	Fixture Controller with 0-10V Dimming, Light Sensing, Wireless Mesh, White Color	12-24VDC	Control High 0-10V Dimming
PSC-ZKV-WCM-100-BLE-CB-BK	Fixture Controller with 0-10V Dimming, Wireless Mesh, Black Color	12-24VDC	Control High 0-10V Dimming
PSC-ZKV-WCM-110-BLE-CB-BK	Fixture Controller with 0-10V Dimming, Light Sensing, Wireless Mesh, Black Color	12-24VDC	Control High 0-10V Dimming
PSC-ZKV-R1L	Receptacle for Fixture Controller	12-24VDC	

Design and specifications are subject to change without notice.