

Casambi Mesh DALI Outdoor Controller with Long Range Antenna

Overview

- Complies with DALI D4i Specifications
- Single Channel DALI Wireless Controller
- Integral Long Range Antenna
- Mounts to Light Fixture/ Luminaire via Zhaga Book18 Quick Connect Receptacle
- Compatible with Casambi Wireless Mesh Systems
- Features High-End and Low-End Trim Adjustment, Zoning & Continuous Dimming
- IP65 Rated for Outdoor or Indoor Applications
- 24VDC or DALI Bus Powered Options
- ioXt Alliance Cybersecurity Certification



For Indoor or Outdoor use



E341446

Summary

Product Type:
Single Channel Wireless DALI Controller with Long Range Antenna

Input Voltage | Current Consumption:
24VDC | 100 mA max (Aux Powered)
16VDC | 100 mA max (DALI Bus Powered)

DALI: Complies with DALI D4i Specifications

Mounting: Mounts to Zhaga Book 18 receptacle (PSC-ZAD-R1L) sold separately

Max Bluetooth Range¹:
1020 feet (310 meters)

Operating Temperature:
-22°F to 158°F (-30°C to 70°C)

Storage Temperature:
-40°F to 185°F (-40°C to 85°C)

Relative Humidity:
90-95% non-condensing at 30°C

Color: Clear/Transparent Housing

Warranty: 5 years

Note:

1. Bluetooth Range is highly dependent on the integration of fixtures, surrounding environment and conditions. It is recommended to conduct testing for Bluetooth range accuracy.

Applications

The PSC-ZAD-WCM/EXA is a single channel DALI D4i wireless fixture controller with a long range antenna.

The controller is IP65 rated and suitable for exterior use.

This device communicates directly with DALI drivers and is controlled wirelessly via Casambi Mesh technology allowing for wireless dimming of luminaires. The compact size allows for seamless integration to the fixture.

Two Power Input options are available. The Aux Powered (-100) model requires 24VDC power to operate. The DALI Bus Powered (-200) model uses DALI Bus power to operate. See the product wiring information for wiring designations.

Operation

Casambi Mesh: The ZAD-WCM/EXA controller is compatible with the Casambi wireless mesh network and configured via a mobile app, available as iOS or Android. The app is used for initial setup and subsequent parameter adjustment.

User Interface: Additional features available via the mobile app include real time control and feedback, and scheduling without a gateway or internet access.

Single Channel Control: The controller provides a single channel of D4i compatible DALI output for driver control.

Quick Connector: The controller mounts to a Zhaga Book18 compliant receptacle (sold separately - mwConnect part #PSC-ZAD-R1L). One receptacle is required for mounting each controller.

See the Casambi Mesh Commissioning User Manual for more information.

Project

Location/Type

Physical Dimensions

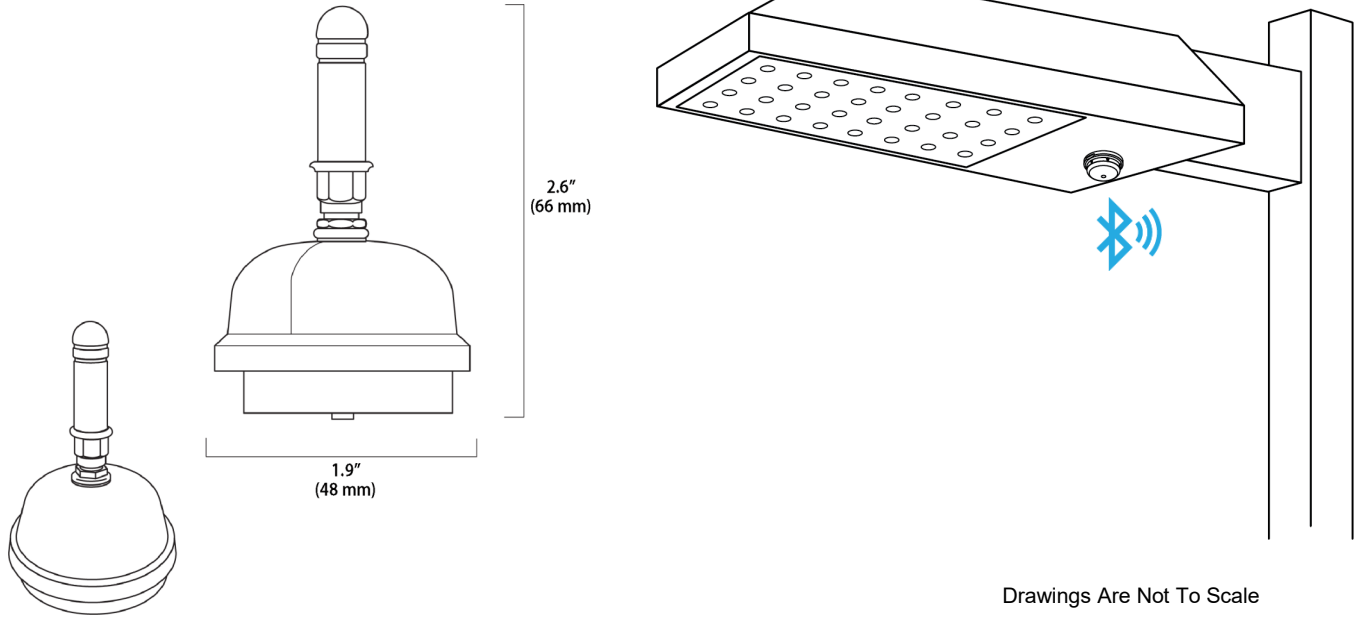

Product Wiring

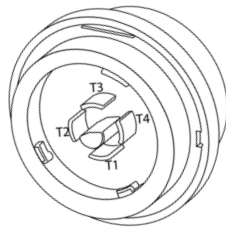

View of Back of Device



View of Zhaga Book 18
Device Receptacle

Tab/Slot	Wiring Designation	
	-100 Aux Powered Models	-200 DALI Bus Powered Models
T1	24VDC+ Power to Sensor-Controller	Reserved
T2	DALI- (Negative DALI Bus) & 24VDC-Ground Power to Sensor-Controller	DALI (16VDC DALI Bus) Polarity Independent
T3	DALI+ (Positive DALI Bus)	DALI (16VDC DALI Bus) Polarity Independent
T4	Reserved	Reserved

For Wiring Diagrams featuring the PSC-ZAD product series, visit the following link:

<http://mwconnect.us/wiring/PSC-ZAD>

Installation of Device

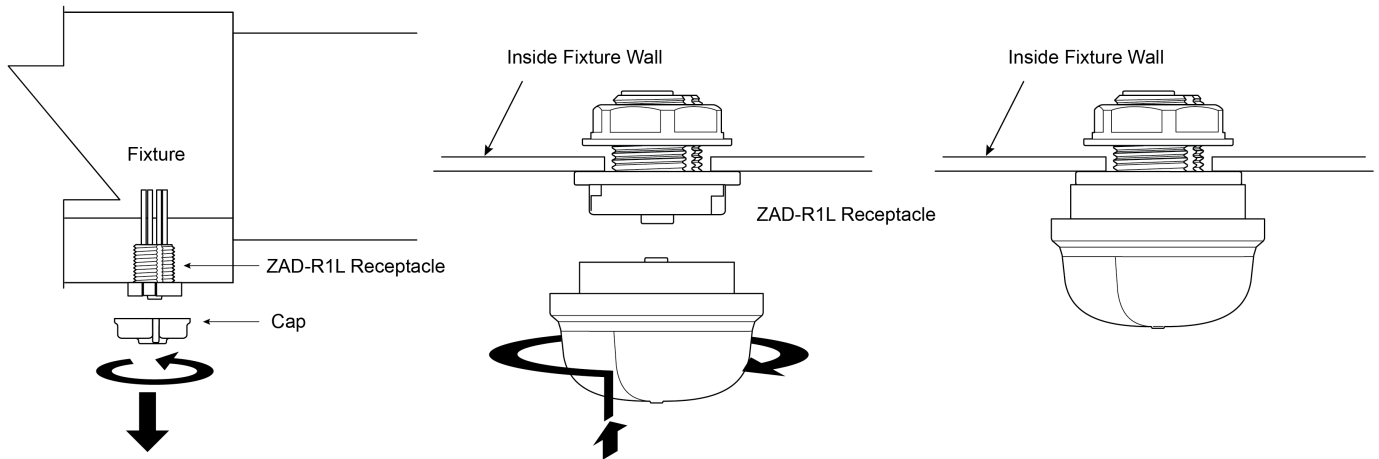

To install a ZAD device, first remove the protective cap on the Zhaga Book 18 receptacle by pushing up and rotating counterclockwise.

To install ZAD devices insert, push in and rotate clockwise to lock. No tools are required. Luminaires can be easily and quickly upgraded.

The receptacle for ZAD devices is typically installed by luminaire manufacturer and is shipped to job site with a protective cap.

How To Order

Model No.	Description	Input Voltage	Output
PSC-ZAD-WCM-100-BLE-CB/EXA	Casambi Mesh Aux Powered DALI Controller with Long-Range Antenna, Clear Housing	24VDC	DALI
PSC-ZAD-WCM-200-BLE-CB/EXA	Casambi Mesh DALI Bus Powered DALI Controller with Long-Range Antenna, Clear Housing	16VDC	DALI
PSC-ZAD-R1L	Zhaga Book18 Quick-Connect Receptacle for use with Sensor-Controllers, Black Finish		

Design and specifications are subject to change without notice.