

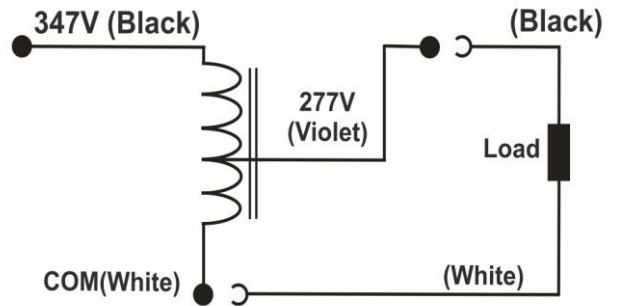

Model No.	<b>MTM00503427C-CAN-BLS</b>
Product Type	<b>Step-down Transformer</b>
Rating (VA)	<b>50</b>
Vin   Vout	<b>347VAC   277VAC</b>
Frequency	<b>60 Hz</b>
Status	<b>Production</b>

Input Voltage (V)		347
Max Input Circuit (A)		0.16
Max Output Circuit (A)		0.18
Max. Load(VA)		50
Output Voltage (V)		277
Full Load	EFF. (%)	92
	THD (%)	6.7
	Power Factor	0.974
UL Class B 130 Temp. Code		A
Case Dimension (inches/mm)	L	4.76/121
	W	2.14/54.5
	H	1.6/40.8
	M	4.35/110.7
	A	3.5/89
	S	0.21/5.5
	B	2.0/50.8
Max Net Weight (lbs)		1.65
Lead Length (inches)		8±0.5

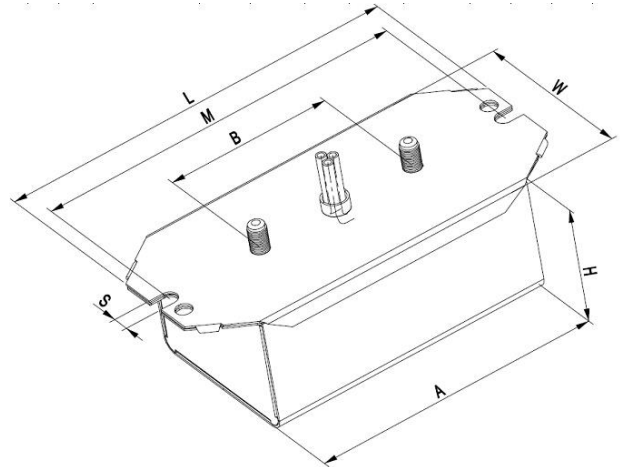

\*Lead Type: (AVLV2), Type 3321, No. 18 AWG (or Equivalent), rated 150°C, 600 V. Strip 10mm Tin Plated.

Product Standards: UL 5085-1, UL 5085-2  
UL CCN: XPTQ2, XPTQ8

Document No.:	<b>PS_MTM_VA0050_34-27_C_CAN_BLS_M01</b>
Date:	<b>2023-03-01 (yyyy-mm-dd)</b>