

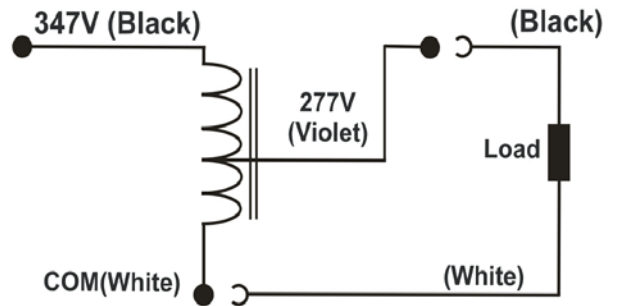

Model No.	MTM01253427C-CAN
Product Type	Step-down Transformer
Rating (VA)	125
Vin Vout	347VAC 277VAC
Frequency	60 Hz
Status	Production

Input Voltage (V)		347
Max Input Circuit (A)		0.39
Max Output Circuit (A)		0.45
Max. Load(VA)		125
Output Voltage (V)		277
Full Load	EFF. (%)	93
	THD (%)	4.9
	Power Factor	0.983
UL Class B 130 Temp. Code		A
Case Dimension (inches/mm)	L	6.53/166
	W	2.33/59.4
	H	1.85/47
	M	6/152.4
	A	5.43/138
	S	0.3/7.8
Max Net Weight (lbs)		3.10
Lead Length (inches)		8±0.5

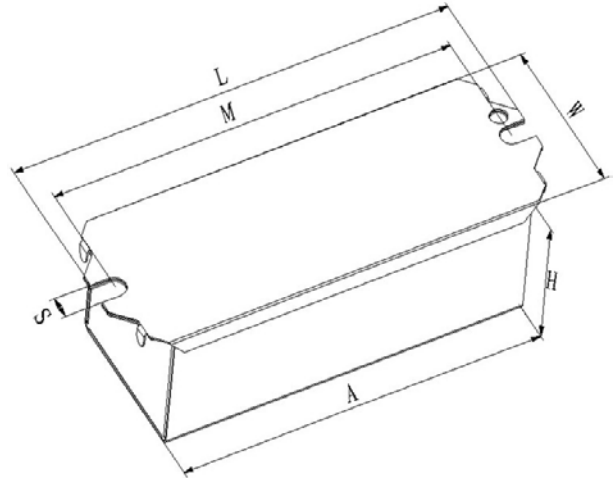

*Lead Type: (AVLV2), Type 3321, No. 18 AWG (or Equivalent), rated 150°C, 600 V. Strip 10mm Tin Plated.

Product Standards: UL 5085-1, UL 5085-2
UL CCN: XPTQ2, XPTQ8

Document No.:	PS_MTM_VA0125_34-27_C_CAN_M01
Date:	2017-03-01 (yyyy-mm-dd)

