

CONSTANT POWER

LINEAR EMERGENCY EQUIPMENT

LEM-Pxx-x00-A-U-Hx



FEATURES



LEM-Pxx-x00-A-U-HT



LEM-Pxx-x00-A-U-HC

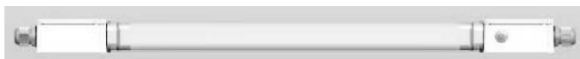

LEM-Pxx-x00-A-U-HE

1. Emergency operation of LED light source and luminaires, for both factory and field installation
2. Perfectly compatible with both DC LED loads and AC LED tubes or bulbs
3. Constant emergency power output, wide range of output voltage from 5 to 300VDC, output current auto adjustable
4. Various emergency power options:

Model #	Emergency Power
LEM-P04-200-A-U-Hx	4.5W
LEM-P09-300-A-U-Hx	9W
LEM-P10-300-A-U-Hx	10W
LEM-P13-300-A-U-Hx	13.5W
LEM-P18-300-A-U-Hx	18W

5. Various connection options:

Type	Connection Type
HT	Terminal block, Integrated Battery
HC	External wires with metal conduits, Integrated Battery
HE	IP66 Waterproof mounting

6. Auto Test
7. Slim aluminum housing
8. **LEM-Pxx-x00-A-U-HT/HC:** Suitable for indoor, dry and damp applications
LEM-Pxx-x00-A-U-HE: IP66 rated. Suitable for outdoor and wet applications

CHARACTERISTICS

Type	LEM-P04-200-A-U -Hx	LEM-P09-300-A-U -Hx	LEM-P13-300-A- U-Hx	LEM-P18-300-A-U -Hx	LEM-P10-300-A-U -Hx
Rated voltage	120-277VAC 50/60Hz				
Rated current	0.03A	0.04A	0.06A	0.08A	0.04A
Rated power	2.7W	3.5W	4.5 W	6W	3.5W
Emergency output power	4.5W	9W	13.5W	18W	10W
Output voltage	5-200VDC	10-300VDC	15-300VDC	20-300VDC	10-300VDC
Output current of AC driver	3A (Max.)				
Operation frequency	320kHz \geq f \geq 50kHz				
Power factor	0.5				
Battery	Li-ion				
Charging time	24 Hours				
Discharge time	>90 Minutes				
Life time	5 Years				
Charging current	0.17A				
Charging cycles	>1000				
Operation temperature	0-50°C (32°F-122°F)				
Efficiency	80%				
Abnormal protection	Over load, over temperature, open circuit, short-circuit protection with auto-reset				
Wire	0.75-1.5mm ²				
EMC& FCC IC standard	EN 55015, EN 61547, EN 61000-3-2, EN 61000-3-3; FCC part 15; ICES-005				
Safety standard	EN 61347-1, EN 61347-2-7, UL924, CSA C.22.2 No. 141				
Meas. LEM-Pxx-x00-A-U-HT mm [inch]	LEM-P04-200-A-U-HT: L200 [7.87] x W30 [1.18] x H22 [0.87] Mounting center: 190 [7.48] LEM-P09-300-A-U-HT: L260 [10.24] x W30 [1.18] x H22 [0.87] Mounting center: 250 [9.84] LEM-P10-300-A-U-HT: L260 [10.24] x W30 [1.18] x H22 [0.87] Mounting center: 250 [9.84] LEM-P13-300-A-U-HT: L345 [13.58] x W30 [1.18] x H22 [0.87] Mounting center: 335 [13.19] LEM-P18-300-A-U-HT: L410 [16.14] x W30 [1.18] x H22 [0.87] Mounting center: 400 [15.75]				
Meas. LEM-Pxx-x00-A-U-HC mm [inch]	LEM-P04-200-A-U-HC: L258 [10.16] x W30 [1.18] x H22 [0.87] Mounting center: 209 [8.23] LEM-P09-300-A-U-HC: L318 [12.52] x W30 [1.18] x H22 [0.87] Mounting center: 269 [10.59] LEM-P10-300-A-U-HC: L318 [12.52] x W30 [1.18] x H22 [0.87] Mounting center: 269 [10.59] LEM-P13-300-A-U-HC: L403 [15.87] x W30 [1.18] x H22 [0.87] Mounting center: 354 [13.94] LEM-P18-300-A-U-HC: L468 [18.43] x W30 [1.18] x H22 [0.87] Mounting center: 419 [16.50]				
Meas. LEM-Pxx-x00-A-U-HE mm [inch]	LEM-P04-200-A-U-HE: L527 [20.75] x W56 [2.20] x H44 [1.73] Mounting center: 462 [18.19] LEM-P09-300-A-U-HE: L587 [23.11] x W56 [2.20] x H44 [1.73] Mounting center: 522 [20.55] LEM-P10-300-A-U-HE: L587 [23.11] x W56 [2.20] x H44 [1.73] Mounting center: 522 [20.55] LEM-P13-300-A-U-HE: L672 [26.46] x W56 [2.20] x H44 [1.73] Mounting center: 607 [23.90] LEM-P18-300-A-U-HE: L737 [29.02] x W56 [2.20] x H44 [1.73] Mounting center: 672 [26.46]				

DIMENSION

LEM-Pxx-x00-A-U-HT



Item No.	L1 mm [inch]	M mm [inch]	W mm [inch]	H mm [inch]
LEM-P04-200-A-U-Hx	200 [7.87]	190 [7.48]	30 [1.18]	22 [0.87]
LEM-P09-300-A-U-Hx	260 [10.24]	250 [9.84]	30 [1.18]	22 [0.87]
LEM-P10-300-A-U-Hx	260 [10.24]	250 [9.84]	30 [1.18]	22 [0.87]
LEM-P13-300-A-U-Hx	345 [13.58]	335 [13.19]	30 [1.18]	22 [0.87]
LEM-P18-300-A-U-Hx	410 [16.14]	400 [15.7]	30 [1.18]	22 [0.87]

Notes:

1. Dimension unit: mm[inch]
2. Dimension tolerance: +/-1[0.04]

DIMENSION

LEM-Pxx-x00-A-U-HC

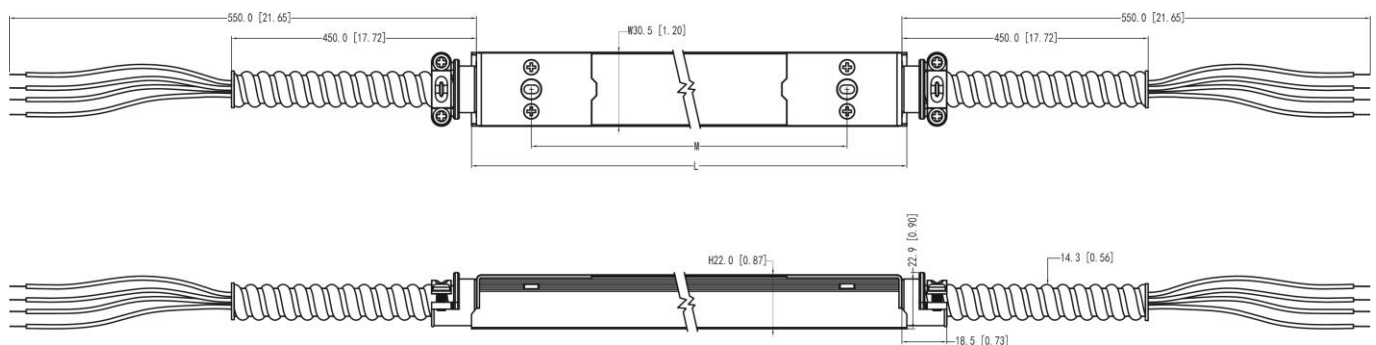

Item No.	L mm [inch]	M mm [inch]	W mm [inch]	H mm [inch]
LEM-P04-200-A-U-Hx	258 [10.16]	209 [8.23]	30 [1.18]	22 [0.87]
LEM-P09-300-A-U-Hx	318 [12.52]	269 [10.59]	30 [1.18]	22 [0.87]
LEM-P10-300-A-U-Hx	318 [12.52]	269 [10.59]	30 [1.18]	22 [0.87]
LEM-P13-300-A-U-Hx	403 [15.87]	354 [13.94]	30 [1.18]	22 [0.87]
LEM-P18-300-A-U-Hx	468 [18.43]	419 [16.50]	30 [1.18]	22 [0.87]

Notes:

1. Dimension unit: mm[inch]
2. Dimension tolerance: +/-1[0.04]

DIMENSION

LEM-Pxx-x00-A-U-HE SURFACE MOUNTING

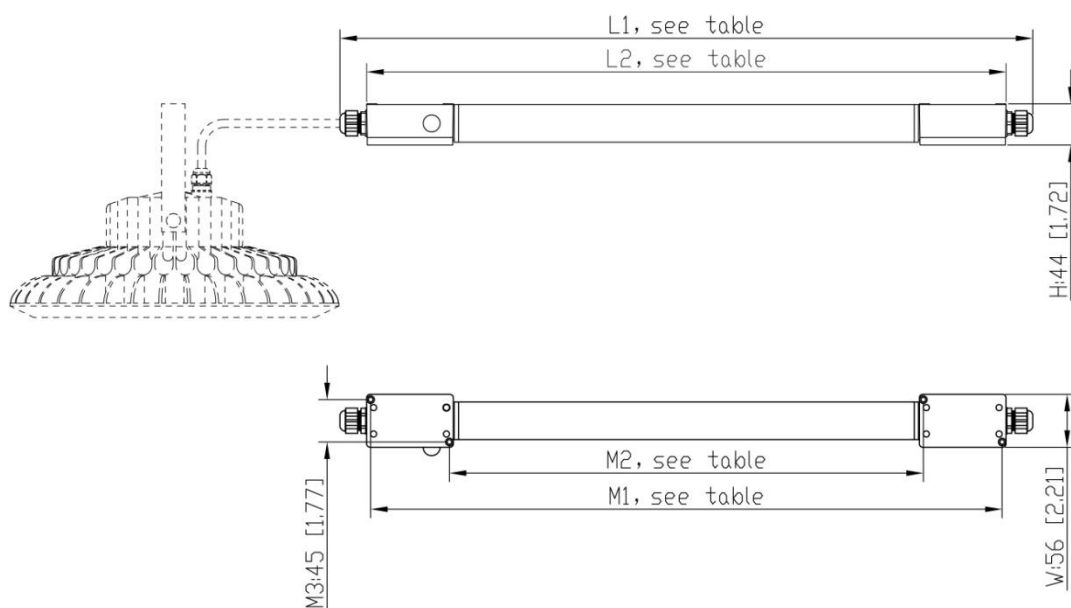

Item No.	L1 mm [inch]	L2 mm [inch]	M1 mm [inch]	M2 mm [inch]	M3 mm [inch]	W mm [inch]
LEM-P04-200-A-U-HE	530±4 [20.87±0.16]	471 [18.54]	460 [18.11]	297 [11.69]	45 [1.77]	56 [2.21]
LEM-P09-300-A-U-HE	590±4 [23.23±0.16]	531 [20.91]	520 [20.47]	357 [14.06]	45 [1.77]	56 [2.21]
LEM-P10-300-A-U-HE	590±4 [23.23±0.16]	531 [20.91]	520 [20.47]	357 [14.06]	45 [1.77]	56 [2.21]
LEM-P13-300-A-U-HE	675±4 [26.57±0.16]	616 [24.25]	605 [23.82]	442 [17.40]	45 [1.77]	56 [2.21]
LEM-P18-300-A-U-HE	740±4 [29.13±0.16]	681 [26.81]	670 [26.38]	507 [19.96]	45 [1.77]	56 [2.21]

Notes:

1. Dimension unit: mm[inch]
2. Dimension tolerance: +/-1[0.04]

DIMENSION

LEM-Pxx-x00-A-U-HE SUSPENSION MOUNTING

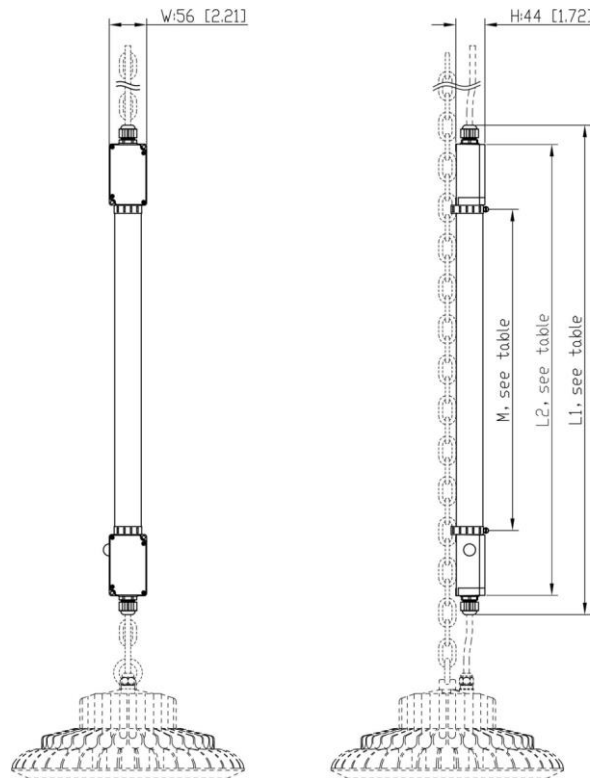

Item No.	L mm [inch]	M1 mm [inch]	M2 mm [inch]	M3 mm [inch]	W mm [inch]	H mm [inch]
LEM-P04-200-A-U-HE	L1 mm [inch]	L2 mm [inch]	M mm [inch]	W mm [inch]	H mm [inch]	L1 mm [inch]
LEM-P09-300-A-U-HE	530±4 [20.87±0.16]	471 [18.54]	274 [10.79]	56 [2.21]	44 [1.72]	530±4 [20.87±0.16]
LEM-P10-300-A-U-HE	530±4 [20.87±0.16]	471 [18.54]	274 [10.79]	56 [2.21]	44 [1.72]	530±4 [20.87±0.16]
LEM-P13-300-A-U-HE	590±4 [23.23±0.16]	531 [20.91]	334 [13.15]	56 [2.21]	44 [1.72]	590±4 [23.23±0.16]
LEM-P18-300-A-U-HE	675±4 [26.57±0.16]	616 [24.25]	419 [16.50]	56 [2.21]	44 [1.72]	675±4 [26.57±0.16]

Notes:

1. Dimension unit: mm[inch]
2. Dimension tolerance: +/-1[0.04]

WIRING CONFIGURATION

LEM-Pxx-x00-A-U-HT/C

FOR AC LED TUBE/BULB/LUMINAIRE

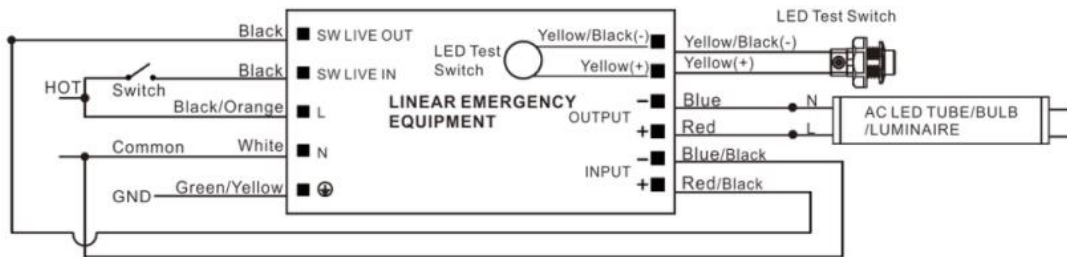

FOR DC LED LOAD

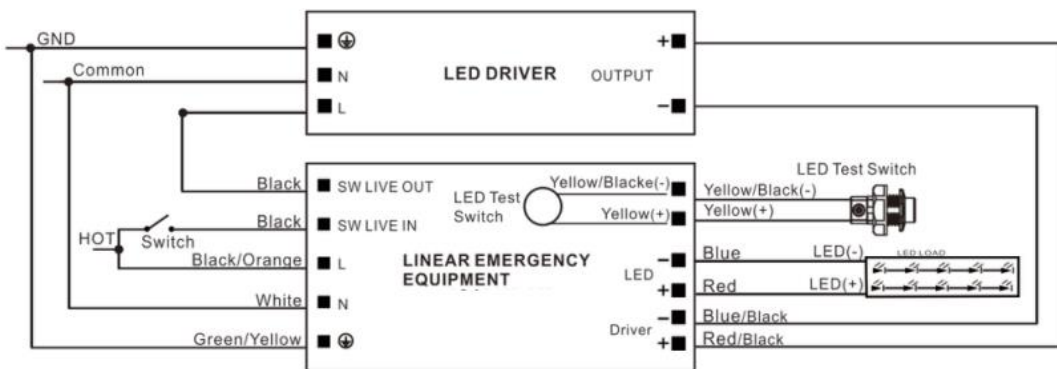

LEM-Pxx-x00-A-U-HE

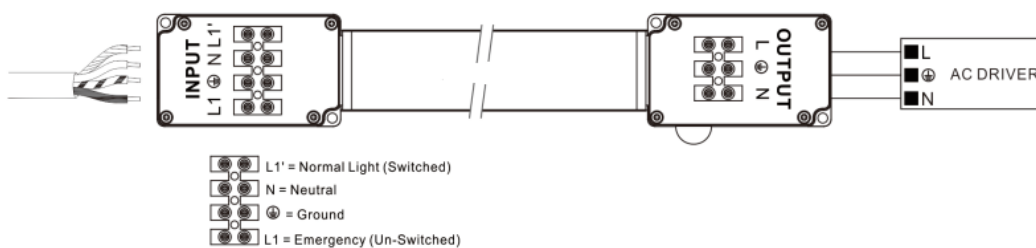

LED TEST SWITCH

LTS-IP20

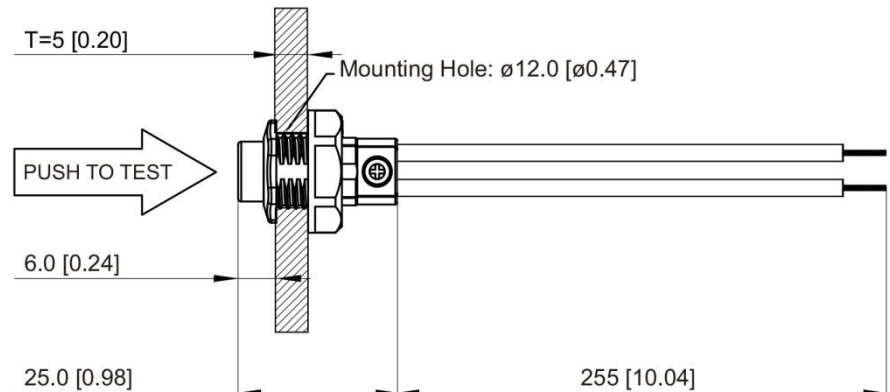

LTS-IP66



Notes:

1. Dimension unit: mm[inch]
2. Dimension tolerance: +/-1[0.04]

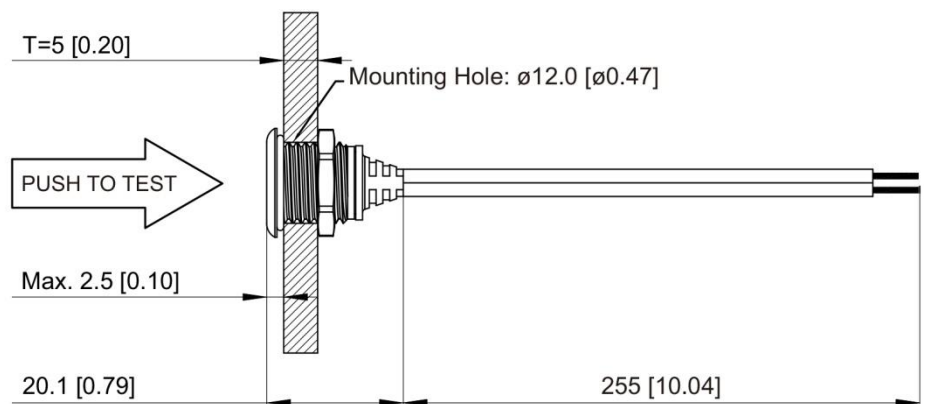

OPERATION/TESTING/MAINTENANCE

OPERATION

When AC power is applied, the LED test switch is illuminated, indicating that the batteries are being charged. When AC power fails, the LEM-Pxx-x00-A-U-Hx automatically switches to emergency power, operating the lighting load at rated emergency power. During power failure, the LED test switch will be off. When the AC power is restored, the emergency LEM-Pxx-x00-A-U-Hx switches the system back to normal mode of operation and resumes battery charging. The minimum emergency operation time is 90 minutes. The charging time for a full discharge is 24 hours.

TESTING AND MAINTENANCE

McWong International, Inc.

1921 Arena Boulevard, Sacramento, California 95834
 Tel: (916) 371-8080 Fax: (916) 371-6666 Email: support@mcwonginc.com

The following Periodic testing is recommended to ensure the system is working correctly.

1. Visually inspect the LED test switch (LTS) monthly. It should be illuminated when AC power is applied.
2. Conduct a 30-second discharge test by switching off the emergency breaker every month. The LTS will be off.
3. Conduct a 90-minute discharge test once per year. The LTS will be off during test.

AUTO TEST

The LEM-Pxx-x00-A-U-Hx has an Auto Test feature which saves cost by reducing the need for manual testing.

1. Initial Auto Test

When the system is connected properly and powered on, the LEM will perform an initial Auto Test.

If any abnormal conditions exist, the LTS will blink quickly. Once the abnormal condition is corrected, the LTS will function correctly.

2. Preprogrammed Scheduled Auto Test

a) The unit will conduct the first Monthly Auto Test after 24 hours and up to 7 days after initial power on.

Then monthly tests will be performed every 30 days.

b) Annual Auto test will occur every 52 weeks after initial power on.

- Monthly Auto Test

The Monthly Auto Test shall be executed every 30 days, and will test;

Normal to emergency transfer function, emergency, charging and discharging conditions are normal.

Monthly test time is approximately 30~60 seconds.

- Annual Auto Test

Annual Auto Test will occur every 52 weeks after the initial 24 hours full charge, and will test;

Proper initial battery voltage, 90-minute emergency operation and acceptable battery voltage at the end of the full 90-minute test.

If the Auto Test is interrupted by a power failure, a full 90-minute Auto Test will occur again 24 hours after the power is restored. If the power failure causes the battery to fully discharge, the product will restart the Initial Auto Test and Preprogrammed Scheduled Auto Test.

OPERATION/TESTING/MAINTENANCE

MANUAL TEST

- Press the LTS 1 time to force a one-second emergency test.
- Press the LTS 2 times continuously within 5 seconds to force a 30-second monthly test. After the test is complete, the next (30-day) monthly test will count from this date.
- Press the LTS 3 times continuously within 5 seconds to force a 90-minute annual test. After the test is completed, the next (52-week) annual test will count from this date.
- During any manual test, press and hold the LTS for greater than 3 seconds to terminate a manual test. The Preprogrammed Scheduled Auto Test time will not change.

LED TEST SWITCH (LTS) INDICATION

- LTS Slow Blinking: Normal Charging
- LTS On: Battery Fully Charged - Normal Condition
- LTS Off: Power Failure

McWong International, Inc.

9/10

- LTS Gradual Change: In Testing Mode
- LTS Quickly Blinking: Abnormal Condition - Corrective Action Required

SAFETY INSTRUCTIONS

1. To prevent electric shock, switch off the mains power supply until installation is complete and AC power is supplied to this product.
2. This product requires an unswitched AC power supply of 120-277V, 50/60Hz.
3. Make sure all connections are in accordance with the National or Canadian Electrical code and any local regulations.
4. To reduce the risk of electrical shock, disconnect both normal and emergency power supplies and connector of this product before servicing.
5. It can provide minimum 90 minutes illumination under the emergency mode.
6. The LEM-Pxx-x00-A-U-Hx are UL Listed for field installation, and use with grounded, UL Listed, damp location rated fixtures.
7. This product is suitable for use in dry or damp locations. Do not mount it near gas, heaters, air outlets or other hazardous locations.
8. Use this product in 0°C minimum, 55°C maximum ambient temperatures (Ta).
9. Do not attempt to service the batteries. A sealed, non-maintenance battery is used that is not field replaceable. Contact the manufacturer for information or service.
10. As this product contains batteries, please be sure to store it in an indoor environment of -20°C ~30°C. It must be fully charged and discharged every 6 months from the date of purchase until it is officially put into use, then recharged 30-50% and stored for another 6 months, and so on. If the battery is not used for more than 6 months, it may cause excessive self-discharge of the battery, and the resulting reduction of battery capacity is irreversible. For products with separate battery and emergency module, please disconnect the connection between battery and module for storage. Due to its chemical properties, it is a normal situation for the battery capacity to decline naturally during use. Users should take this into account when choosing products.
11. The use of accessory equipment not recommended by the manufacturer may cause an unsafe condition and void warranty.
12. Do not use this product for other than intended use.
13. Installation and service should be performed by qualified service personnel.
14. This product should be mounted in locations and at heights where it will not readily be subjected to tampering by unauthorized personnel.
15. Ensure product compatibility before final installation. Wiring should be strictly in accordance with the wiring diagram, wiring errors will damage the product. A case of safety accident or product failure caused by users' illegal operation does not belong to the scope of customer complaint acceptance, compensation or product quality assurance.