



## MINI INVERTER

PURE SINUSOIDAL AC OUTPUT

OUTPUT VOLTAGE AUTO SETTING EQUAL TO INPUT VOLTAGE

LEM-INV-100-U-V1 / LEM-INV-200-U-V1

## FEATURES

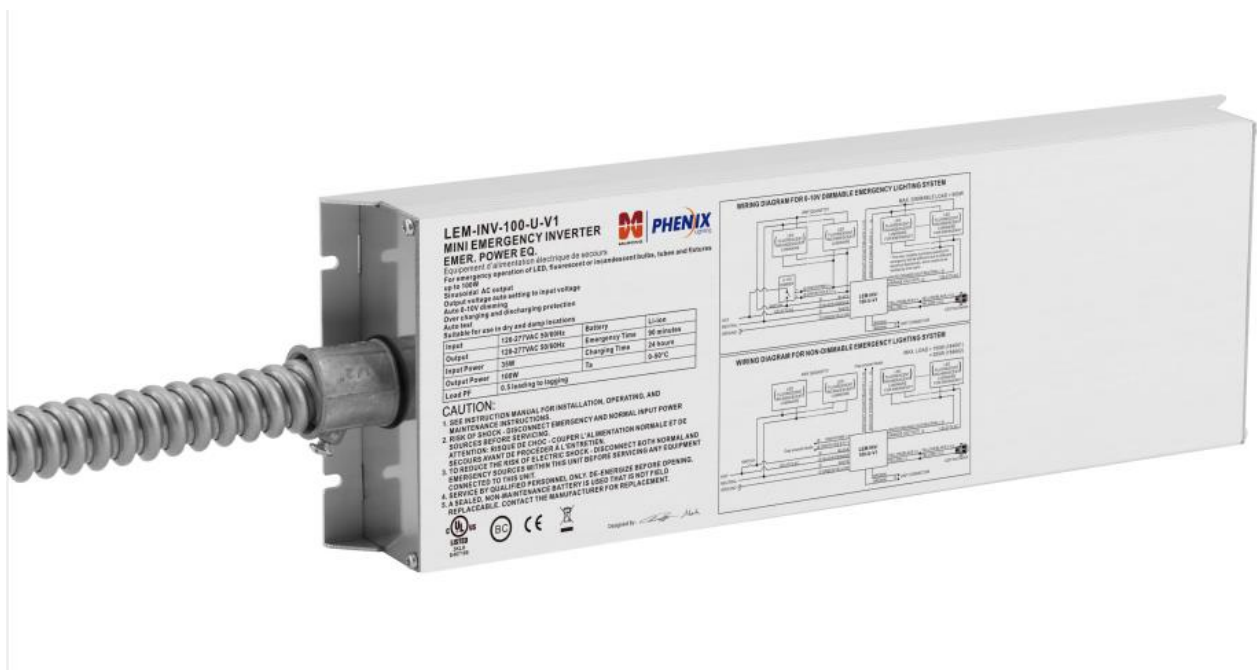

1. Pure sinusoidal AC output
2. Patented APD technology - Auto Preset Dimming (0-10V) the connected load in emergency mode
3. Output voltage auto setting according to different input voltages
4. Auto Test
5. Extremely slim aluminium housing and light in weight
6. Suitable for indoor, dry and damp applications

## CHARACTERISTICS

Type	LEM-INV-100-U-V1	LEM-INV-200-U-V1
Lamp type	LED, fluorescent or incandescent bulbs, tubes and lighting fixtures	
Rated voltage	120-277VAC 50/60Hz	
Rated current	0.48A@120V	
Rated power	35W	
Power factor	0.5 leading to lagging	0.9 leading to lagging
Output voltage	120-277VAC 50/60Hz	
Output power	100W	200W
Max. power of 0-10V dimming load	900W	
Battery	Li-ion	
Charging time	12 Hours	24 Hours
Discharge time	90 Minutes	
Charging current	0.6A	
Lifetime	5 Years	
Charging cycles	>1000	
Operation temperature	0-50°C (32°F -122°F)	
Efficiency	84%	85%
Abnormal protection	Over voltage, over current, Inrush current limiting, over temperature, short circuit, open circuit	
Wire	16-18AWG/0.75-1.5mm <sup>2</sup>	
EMC/FCC/IC standard	EN 55015, EN 61547, EN 61000-3-2, EN 61000-3-3, FCC part 15, ICES-005	
Safety standard	EN 61347-1, EN 61347-2-7, UL924, CSA C.22.2 No. 141	
Meas. mm [inch]	L346 [13.63] x W115 [4.53] x H41.5 [1.63] Mounting center: 338 [13.31]	L479 [18.86] x W115 [4.53] x H41.5 [1.63] Mounting center: 471 [18.55]

**DIMENSION**

**LEM-INV-100-U-V1 / LEM-INV-200-U-V1**

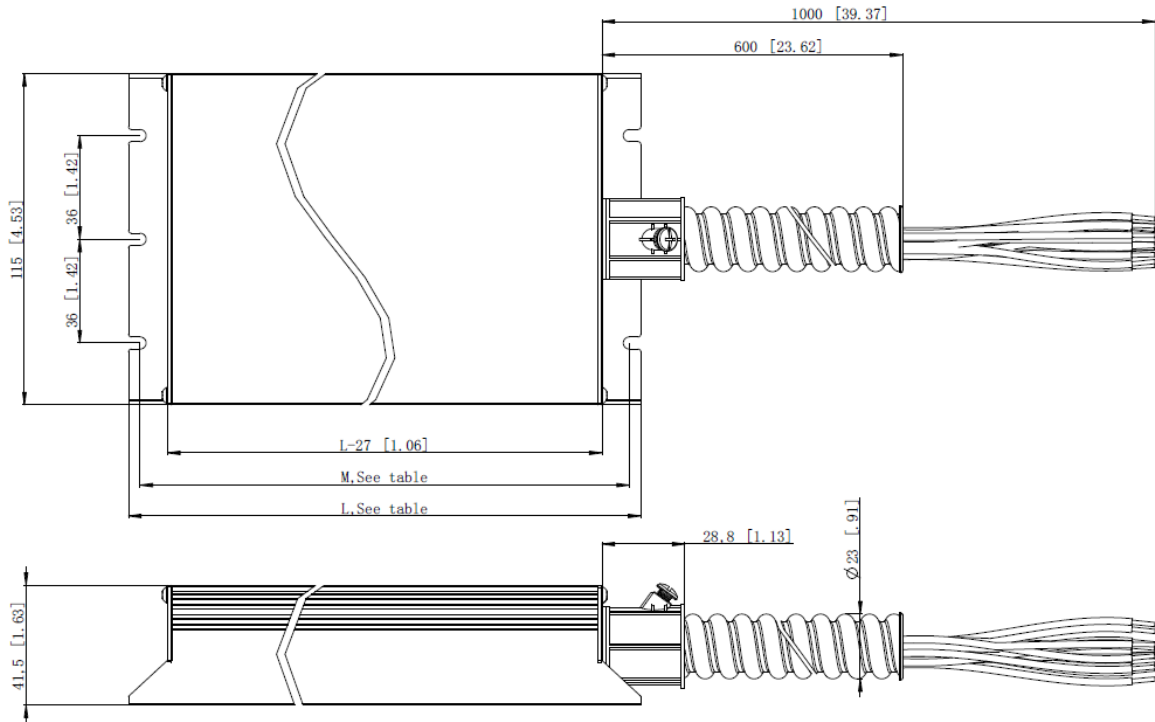

Item No.	L mm [inch]	M mm [inch]	W mm [inch]	H mm [inch]
LEM-INV-100-U-V1	346 [13.63]	338 [13.31]	115 [4.53]	41.5 [1.63]
LEM-INV-200-U-V1	479 [18.86]	471 [18.55]	115 [4.53]	41.5 [1.63]

Dimension unit: mm [inch]

Tolerance:  $\pm 1$  [0.04]

**LED TEST SWITCH**

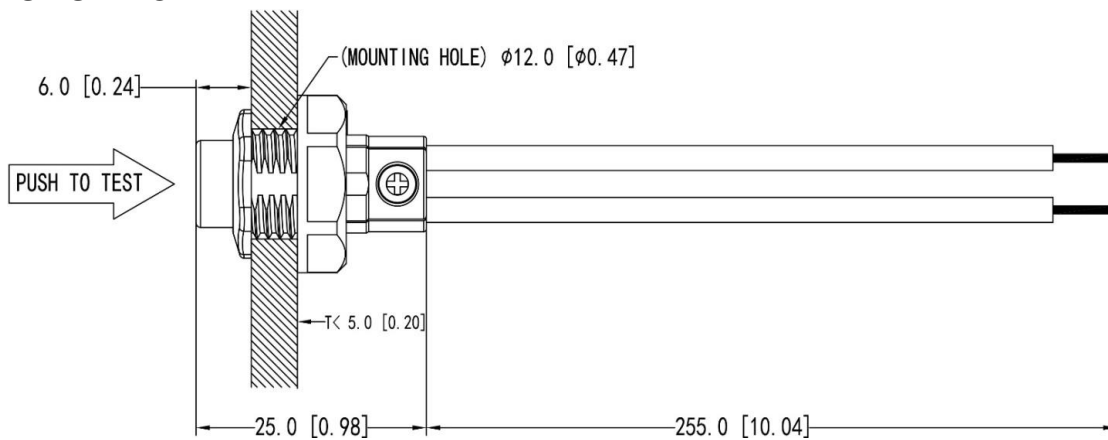

Dimension unit: mm [inch] / Tolerance:  $\pm 1$  [0.04]

WIRING DIAGRAM

WIRING DIAGRAM FOR 0-10V DIMMABLE EMERGENCY LIGHTING SYSTEM

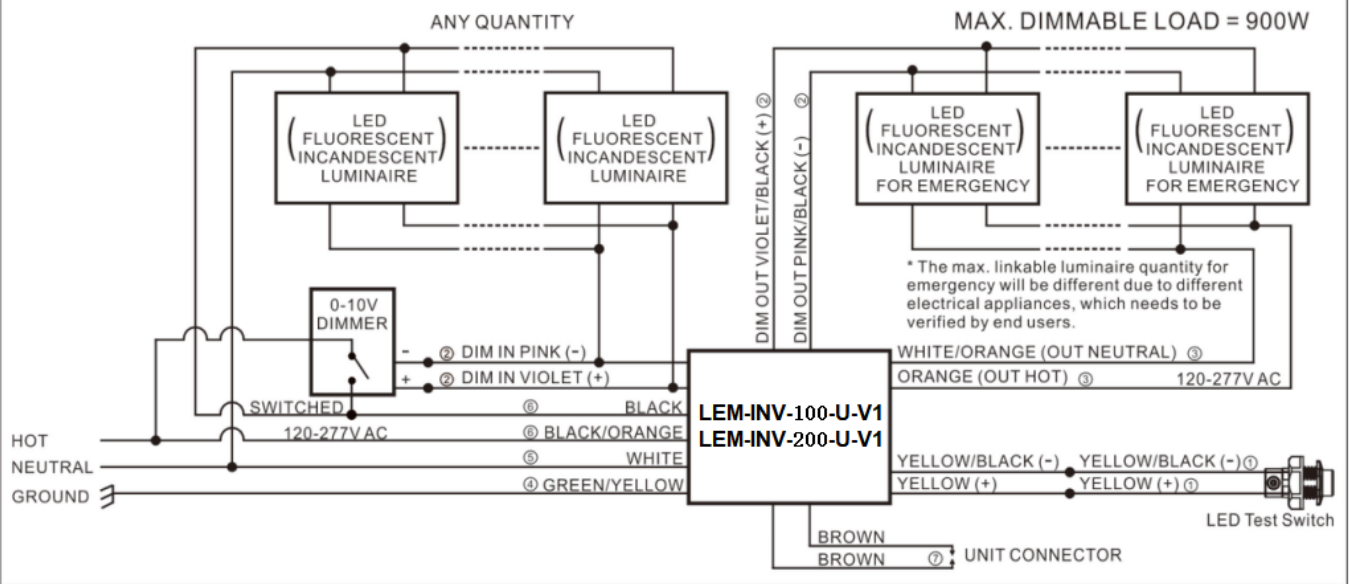

WIRING DIAGRAM FOR NON-DIMMABLE EMERGENCY LIGHTING SYSTEM

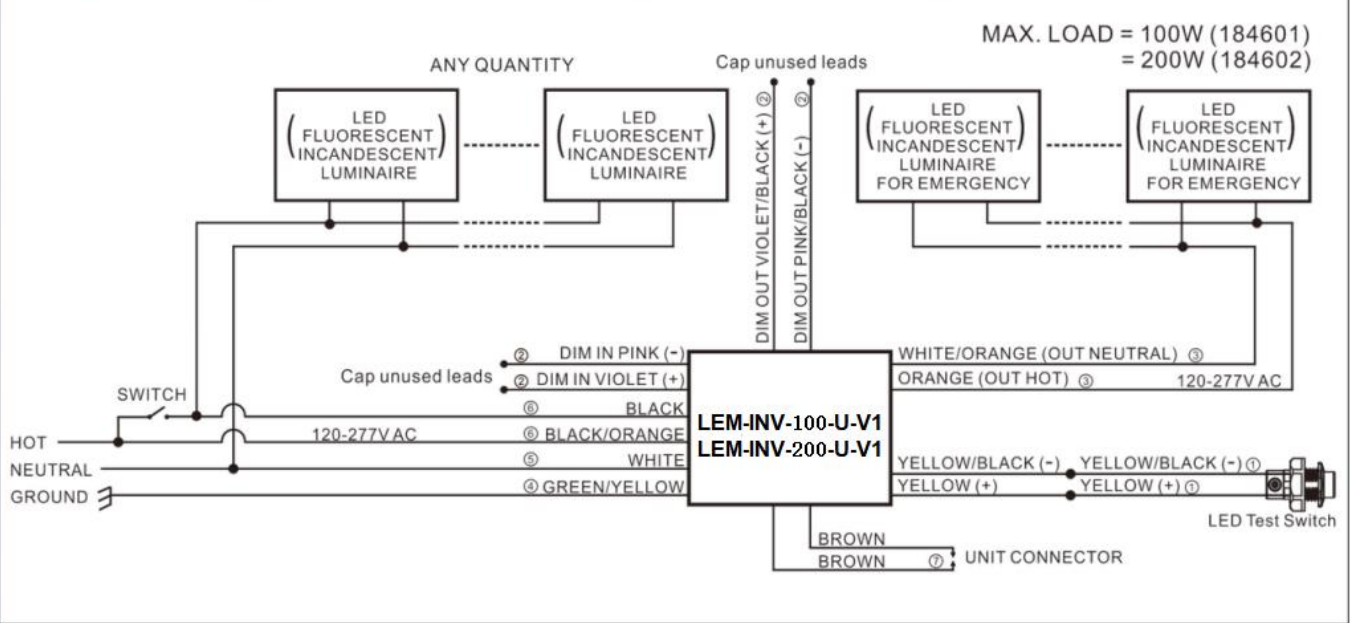

## **OPERATION/TESTING/MAINTENANCE**

### **OPERATION**

When AC power is applied, the LED test switch is illuminated, indicating that the batteries are being charged. When AC power fails, the LEM automatically switches to emergency power, operating the lighting load at rated emergency power. During power failure, the LED test switch will be off. When the AC power is restored, the LEM switches the system back to normal mode of operation and resumes battery charging. The minimum emergency operation time is 90 minutes. A short term discharge test may be conducted after unit has been charging for 1 hour. The charging time for the full discharged battery of LEM-INV-100-U-V1 is 12 hours, LEM-INV-200-U-V1 is 24 hours.

### **TESTING AND MAINTENANCE**

The following Periodic testing is recommended to ensure the system is working correctly.

1. Visually inspect the LED test switch (LTS) monthly. It should be illuminated when AC power is applied.
2. Conduct a 30-second discharge test by switching off the emergency breaker every month. The LTS will be off.
3. Conduct a 90-minute discharge test once per year. The LTS will be off during the test.

### **AUTO TEST**

The LEM has an Auto Test feature which saves cost by reducing the need for manual testing.

#### **1. Initial Auto Test**

When the system is connected properly and powered on (make sure the load is switched on), the LEM will perform an Initial Auto Test. If any abnormal conditions exist, the LTS will blink quickly. Once the abnormal condition is corrected, the LTS will function correctly.

The Initial Auto Test will be restarted automatically when the connected dimmable loads' maximum power increases.

#### **2. Preprogrammed Scheduled Auto Test**

a) The unit will conduct the first Monthly Auto Test after 24 hours and up to 7 days after initial power on. Then monthly tests will be performed every 30 days.

b) Annual Auto test will occur every 52 weeks after initial power on.

##### **- Monthly Auto Test**

The Monthly Auto Test shall be executed every 30 days, and will test:

Normal to emergency transfer function, emergency, charging and discharging conditions are normal. Monthly test time is approximately 60 seconds.

##### **- Annual Auto Test**

Annual Auto Test will occur every 52 weeks after the initial 24 hours full charge, and will test:

Proper initial battery voltage, 90-minute emergency operation and acceptable battery voltage at the end of the full 90-minute test.

If the Auto Test is interrupted by a power failure, a full 90-minute Auto Test will occur again 24 hours after the power is restored. If the power failure causes the battery to fully discharge, the product will restart the Initial Auto Test and Preprogrammed Scheduled Auto Test.

### **MANUAL TEST**

1. Press the LTS one time to simulate emergency mode for 10 seconds.
2. Press the LTS 2 times continuously within 3 seconds to force a 60-second monthly test. After the test is completed, the next (30-day) monthly test will count from this date.
3. Press the LTS 3 times continuously within 3 seconds to force a 90-minute annual test. After the test is completed, the next (52-week) annual test will count from this date. Note - the product must be 24-hour fully charged.
4. In normal mode, press and hold the LTS for greater than 3 seconds to restart Initial Auto Test.
5. During any manual test, press and hold the LTS for greater than 3 seconds to terminate a manual test. The Preprogrammed Scheduled Auto Test time will not change.

### **LED TEST SWITCH CONDITIONS**

LTS Slow Blinking: Normal Charging

LTS On: Battery Fully Charged - Normal Condition

LTS Off: Power Failure

LTS Gradual Change: In Testing Mode

LTS Quickly Blinking: Abnormal Condition - Corrective Action Required